









Octiv™ Poly 2.0

RF Voltage and Current Sensors





The future of real-time plasma process monitoring

The Octiv Poly 2.0 VI probe is the most advanced RF sensor on the market for in-line power and impedance measurement with unrivalled accuracy and functionality. With 1% true accuracy, chamber-to-chamber matching and process repeatability can be established with confidence. Uniquely convenient form-factors enable retrofitting to match box outputs to facilitate direct plasma monitoring. Issues such as product scrap events, endpoint detection errors and unnecessary preventative maintenance can all be eliminated with this advanced VI probe technology.

Key Features

-  Choice of 5 frequencies on a single sensor with up to 15 harmonics at each frequency.
-  Unrivalled power accuracy into 50 Ω and non-50 Ω load impedances through our advanced calibration methodology (1% true accuracy).
-  Sensor run-to-run repeatability (< 0.1%), enabling a true gauge of plasma process drift.
-  Live Smith Chart view, with impedance accuracy comparable to offline vector network analysers.
-  Frequency tracking to ± 10% of the fundamental frequency as standard, customisable for intermodulation frequency monitoring.
-  Superior Pulsed RF capability with live pulse frequency and duty cycle monitoring and “time resolved” mode.
-  USB, Ethernet, EtherCAT and Serial communication protocols with easy-to-use APIs for integrations.

Key Benefits & Applications

-  Clean and etch endpoint capabilities with Plasma Impedance Monitoring (PIM) and harmonic spectrum techniques.
-  Demonstrated detection of etch endpoint for < 1% open area ratio, with significantly higher sensitivity compared to multivariate OES endpoint detectors.
-  Detects wafer placement issues, air leaks, cross-process contamination, and many other common plasma faults.
-  Gauges overall chamber health, removing the need for unnecessary preventative maintenance actions.
-  Significant cost benefits through the enablement of fault detection and early intervention.

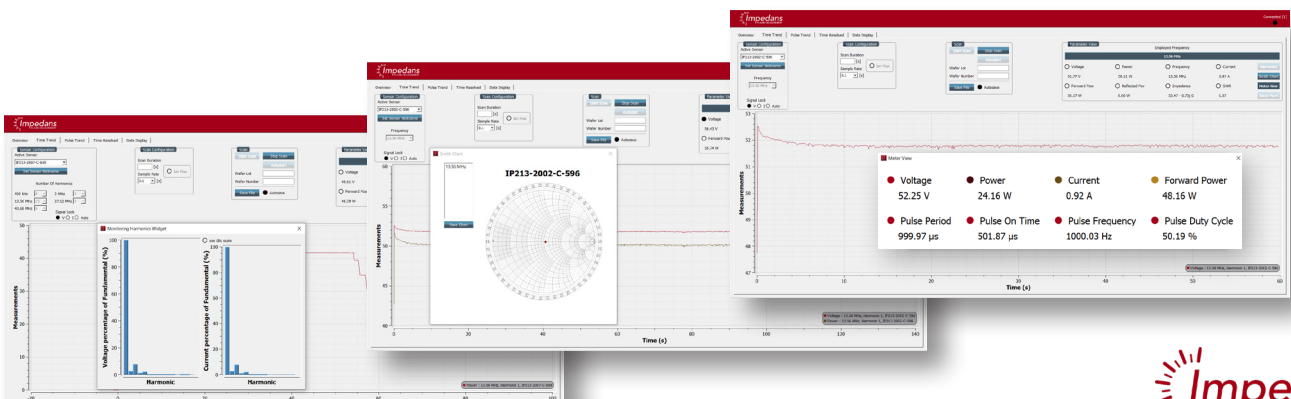

Model Specifications

Model #	Fwd Power Range*	Frequency Range*	Connector Interface
02-0232-02	1.5 W - 12 kW	350 kHz - 240 MHz	QC Type
02-0324-01	0.5 W - 5 kW	40 kHz - 4 MHz	QC Type
02-0307-01	1.5 W - 12 kW	350 kHz - 240 MHz	B6N Multicontact Socket
02-0314-01	1.5 W - 12 kW	350 kHz - 240 MHz	B20N Multicontact Socket
02-0252-01	3 W - 30 kW	350 kHz - 240 MHz	EIA 1-5/8"
02-0306-01	9 W - 90 kW	350 kHz - 240 MHz	EIA 3-1/8"

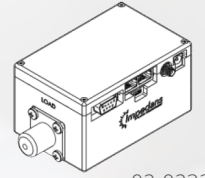

02-0232-02

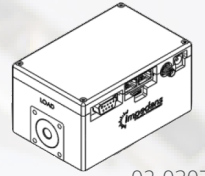

02-0307-01

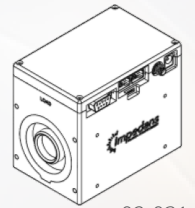

02-0314-01

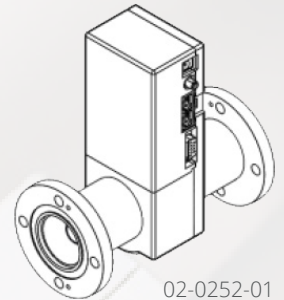

02-0252-01

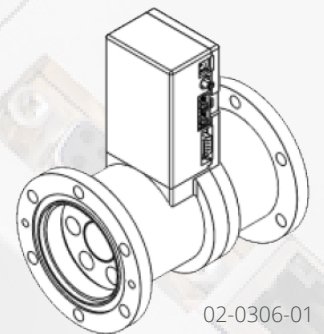

02-0306-01

General Specifications

Calibration Standard	NIST traceable [Power, Impedance]
Calibration Cycle	1 year to maintain quoted accuracy
Sensor Characteristic Impedance	50 Ohms as standard
RF Connectors	QC, EIA and custom options
RF Power Range @ 50 Ohms impedance	Standard: 12 kW typical (connector dependent) High Power: 30 kW & 90 kW
Operating Temperature Range	10° C - 80° C, calibrated versus temperature
Sensor Power Requirements	15-24 V DC, 0.5 A
Communication Interfaces	Micro USB, RJ45x2
Connectivity (Impedans Software)	USB 2.0, Ethernet
Communication Protocols (Standard)	USB 2.0, HTTP Web Service, Serial, RS232
Communication Protocols (OEM Options)	EtherCAT, EtherNet/IP
Parameter Report Rate (Standard)	USB: 500 S/s, Ethernet: 10 S/s, Serial: 10 S/s
Parameter Report Rate (Upgrade Options)	USB: 500 S/s or EtherCAT: 50 S/s
Sensor Pulse Synchronisation	External sync: TTL input Internal sync: Software level trigger

Power, Voltage & Current Specifications

Power Dynamic Range	> 40 dB
Power Range	See model specifications
Power Resolution	0.25 W
Power Uncertainty (95% confidence)	±1%
Voltage Dynamic Range	80 dB
Voltage Range (Typical)	0.3 V to 3000 V _{RMS} , custom available up to 34 kV _{pk-pk}
Voltage Resolution	0.1 V _{RMS}
Voltage Uncertainty (95% confidence)	±1%
Current Dynamic Range	80 dB
Current Range	2.5 mA _{RMS} to 9 A _{RMS} , custom available up to 500 A _{RMS}
Current Resolution	2.5 mA _{RMS}
Current Uncertainty (95% confidence)	±1%

*Custom options available

Publication list available at: impedans.com/octiv-publications



N Type (M)



N Type (F)

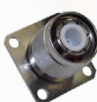

HN (M)



HN (F)



C Type



7/16 (F)



7/16 (M)



LC (F)



LC (M)



EIA (M)



EIA (F)